

Shell Forming & Baffle Stuffing Machine and Head Press Sizing Machine for Automotive Exhaust Systems Assembly Line

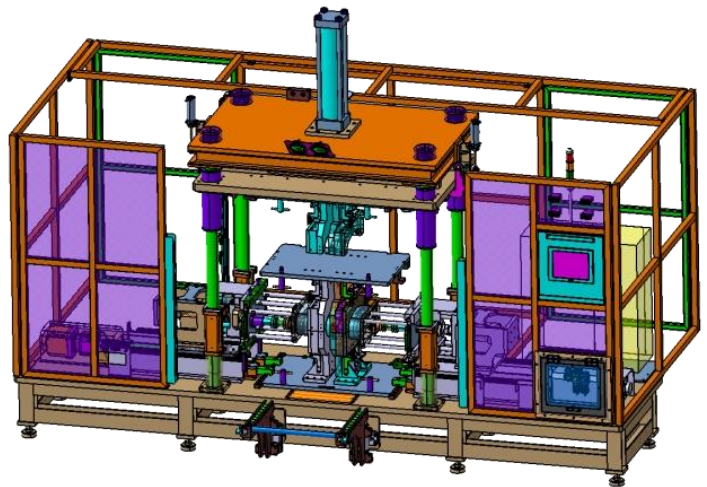
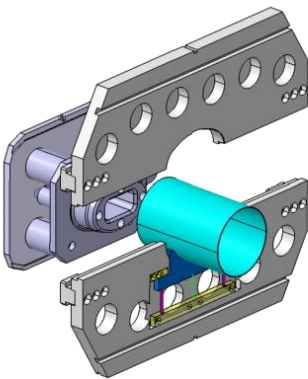

LPR GLOBAL

344 Bloor Street W, Suite 607, Toronto, ON Canada M5S 3A7

www.lprglobal.com | www.uskoreahotlink.com

Tel.: +1 416-423-5590

E-Mail: info@lprglobal.com

Muffler/Resonator/Catalytic Converter Assembly Lines

The traditional automotive muffler manufacturing line consists of 8 sub-processes when categorized by the job. With increased machine and tooling versatility, these processes can be performed simultaneously or in sequence by 3 machines, whereas conventional muffler manufacturing lines would require 7 machines before leak testing.

This business case focuses on our tube forming and shrinking technology within the exhaust system manufacturing line, including the muffler, resonator and catalytic converter assemblies.

All our machines are designed with mistake-proof or poka-yoke techniques. We offer various configurations and customization options to our clients depending on their budget, cycle time, degree of automation and customer-specific safety standards.

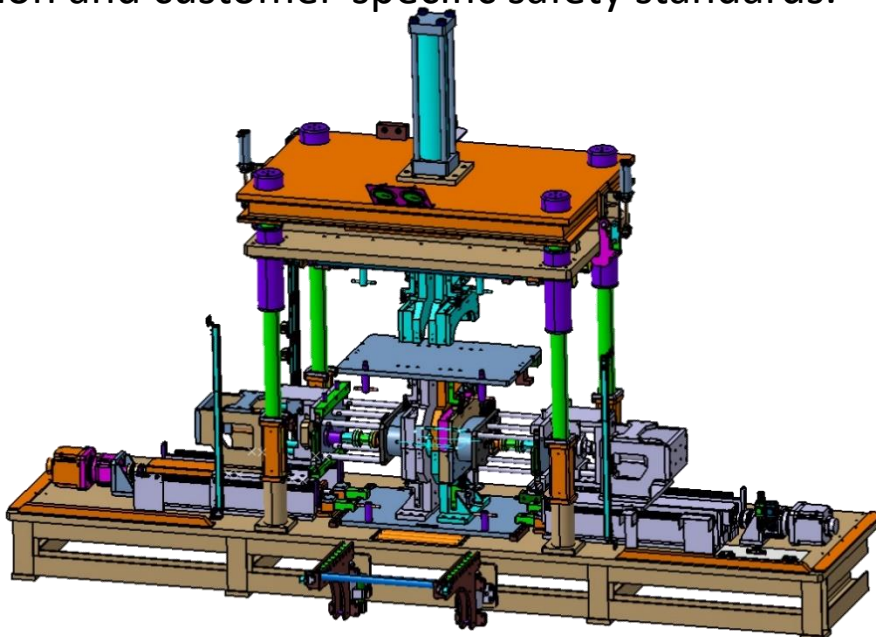

Muffler Shell Forming & Baffle Stuffing Machine

Project Description

The muffler pictured below is produced by 3 machines: a case forming and baffle insertion machine, a double headed baffle insertion and ridge-locking machine, and a CO2 welding machine. We use a double-headed baffle insertion and ridge-locking process because the muffler has 3 layers of baffles inside.

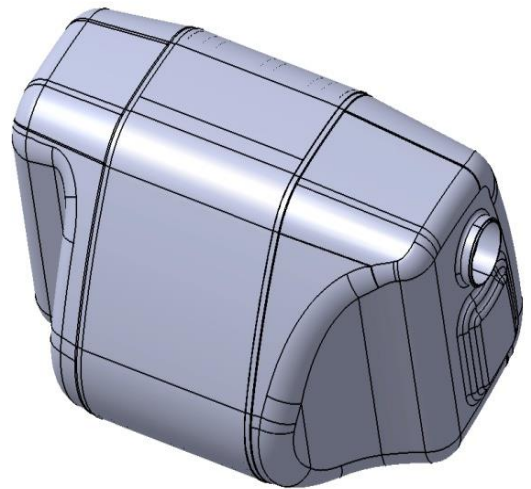
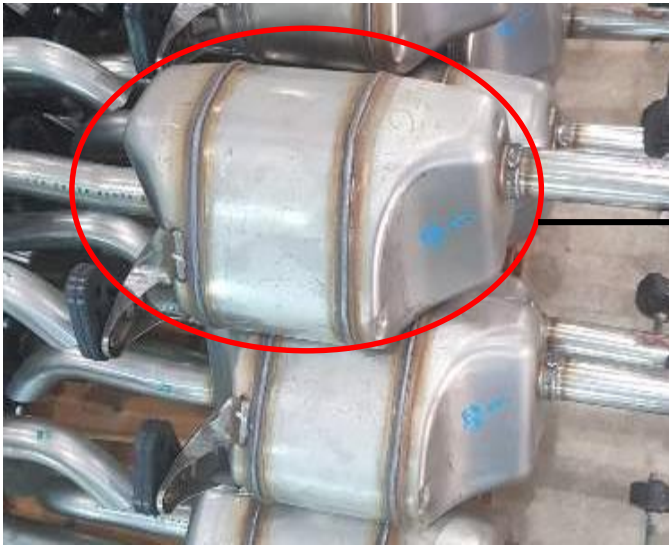

3 layers of baffles
2 pipes

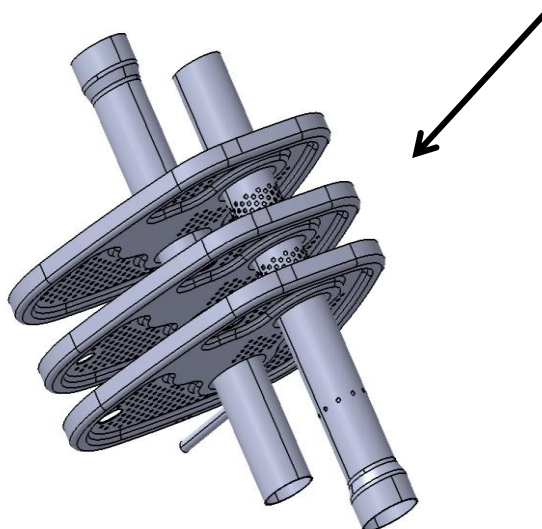

Muffler Shell Forming & Baffle Stuffing Machine

Muffler Forming and Baffle Insertion Process

The tube forming technology is applied to our muffler shell forming and baffle stuffing machine. There are two ways to form shells and insert baffles. Some clients prefer to TIG weld the shell for casing and then use our shell forming and baffle stuffing machine below.



- 1) Material Loading – We install sensors to detect material orientation and weight, to ensure that the materials are not loaded in the wrong direction or as two sheets stuck together.
- 2) TIG Welding and Marking – Weld and mark the casing
- 3) Case Forming & Stuffing Machine – Our machine forms the case shapes by using the patented clamp technology while jacket stuffing tools on both sides insert baffles into the tube simultaneously.

Muffler Shell Forming & Baffle Stuffing Machine

Muffler Forming and Baffle Insertion Process

The other way to form the shell and stuff baffles is to use the machine below, equipped with functions of oval-casing, insertion, tube forming and baffle insertion.

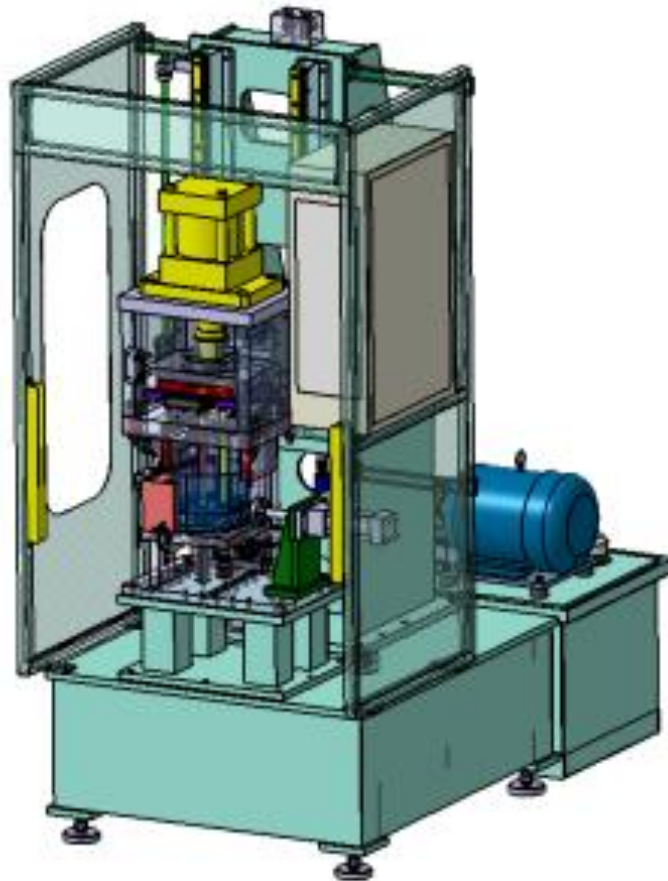

This machine's advantage is shorter cycle time and smaller footprint for the muffler assembly line compared to the previous process. Both machines are equipped with the patented clamp technology.

End Cap Fitting & Shrinking Machine

End Cap Fitting and Shrinking Process

End cap shrinking has recently been introduced as an effective way to prevent welding defects and leakage.

The machine pictured below performs end cap insertion, shrinking of the gap between the end cap and the tube, and expanding the pipe end on the end cap. Another variation of the machine has the same functions, without pipe end expanding.

On the next page we will further discuss how the shrinking process works and whether shrinking and resizing create visible lines.



End Cap Fitting & Shrinking Machine

We are often asked about the advantages of the shrinking process when fitting end caps onto the tube. The shrinking process is used to compensate for the gap of 0.2-0.3 mm between the end cap and the tube/shell that occurs after the end caps are fitted on the tube. Key benefits include drastic reduction of leakage by preventing welding defects. Many of our customers' engineers often ask us whether the shrinking process will leave any mark on the tube. Our answer is no – since shrinking is different from clinching, the muffler doesn't show any marks visible to the naked eye.

With regards to end cap insertion, we also get asked how we avoid any collisions between the muffler shell/tube and the end cap. We slightly expand the shell so that there are no collisions between the shell and the end cap during the shell forming process. In the image below, the part on top is the muffler tube, and the part on the right is the end cap inserted. The muffler tube is slightly expanded.

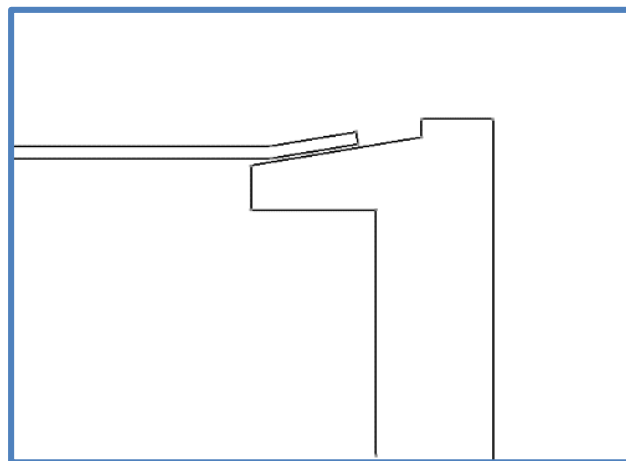

End Cap Fitting & Shrinking Machine

Here is the look of the end cap-inserted muffler produced by our end cap fitting and shrinking machine. The circled pipe end highlights why some clients choose our machine configuration with the pipe end expanding function.

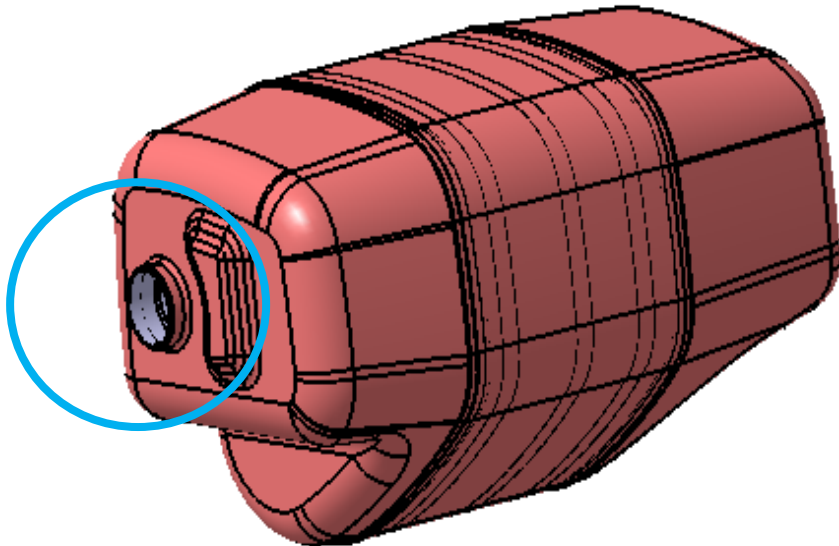
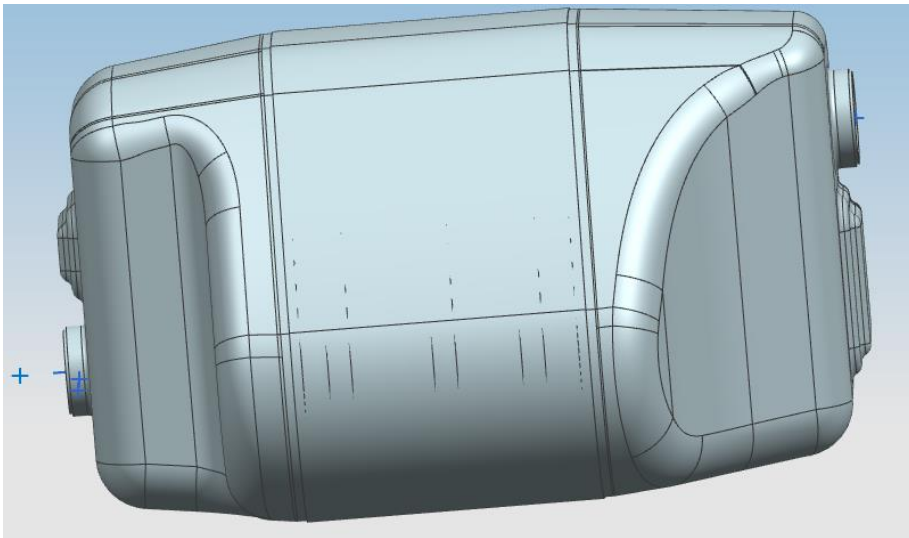

End Cap Fitting & Shrinking Machine

Quick-Change Tooling Design

Our machine designs are known for their versatility; they can easily handle several muffler model productions with minimal tool changeover time. The picture below shows how the operator can change tools within 10 minutes.

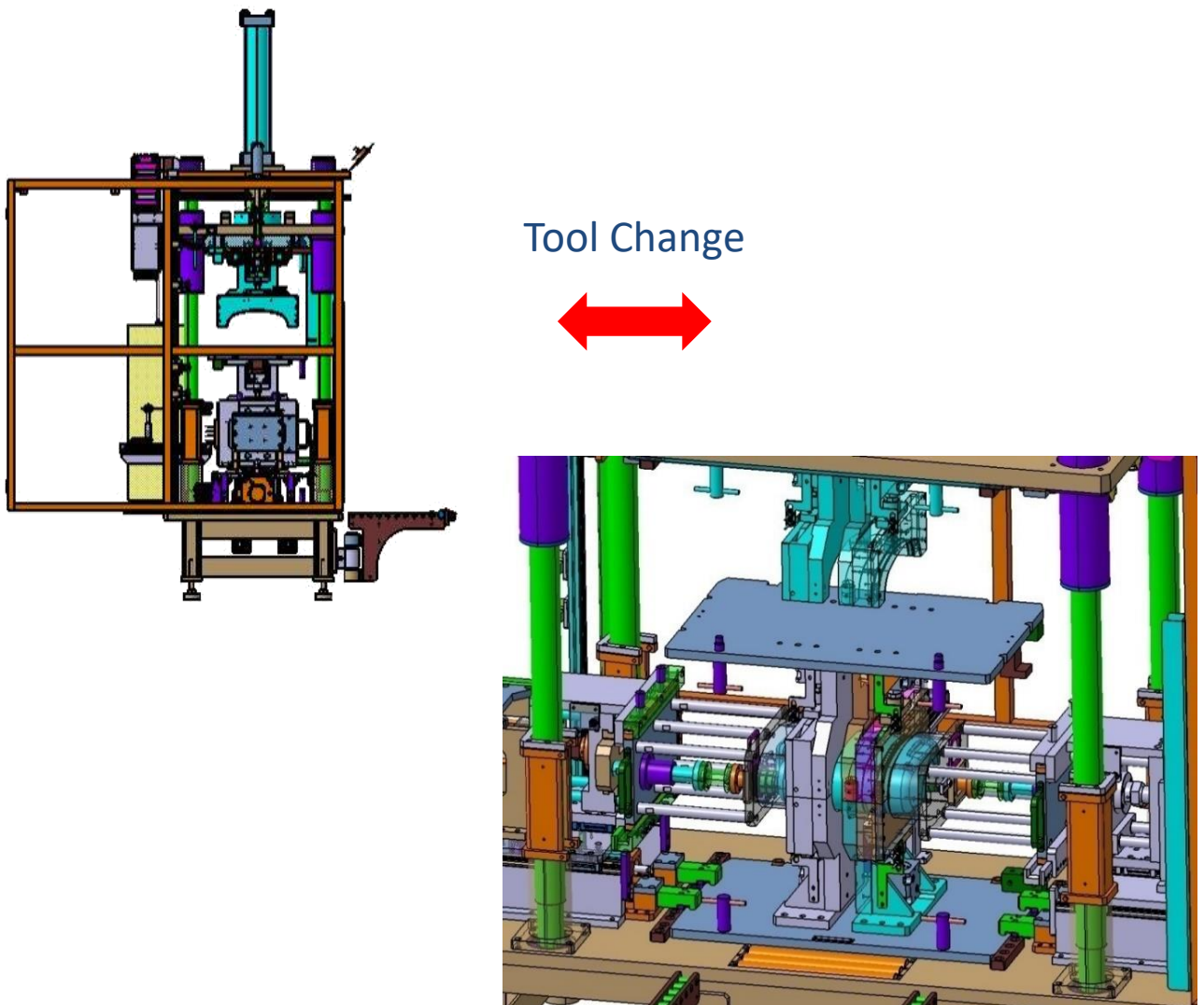

CO2 Welding Machines for Resonators

Double Headed Welding Station

The picture below shows our double headed CO2 welding station for welding the both ends of the resonator simultaneously. This welding station can be fully automated with a robot at the client's request.





LPR Global, Inc.

344 Bloor Street W, Suite #607 Toronto, ON M5S 3A7 Canada

www.lprglobal.com | www.uskoreahotlink.com

Tel: +1 416-423-5590

E-Mail: info@lprglobal.com

