

KNIFE GATE VALVE

Applicable for Slurry/Pulp/Ash

SPECIFICATION

1. MSS SP- 81 specification for 150PSI
2. Flanges per ANSI B16.5
3. Size : 3" ~ 24"
4. Fluid : Pulp, Paper, Slurry, Ash, Coal, Oil, Chemical

SPECIFICATION

1. MSS SP- 81 specification for 150PSI
2. Flanges per ANSI B16.5
3. Size : 3" ~ 30"
4. Fluid : Pulp, Paper, Slurry, Ash, Coal, Oil, Chemical

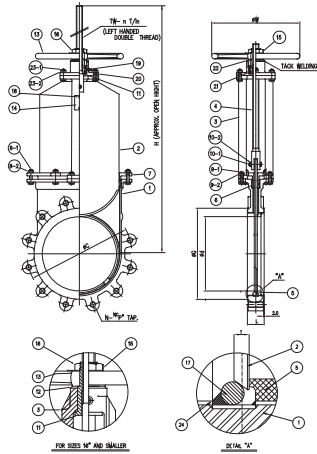

STAINLESS STEEL LINED METAL SEAT / RESILIENT SEAT KLM/KLR

Standard Materials

NO.	DESCRIPTION	MAT'L	Q'TY	REMARK
1	BODY	A536-DCI	1	
2	DISC	A240-304	1	
3	YOKE	A216-WCB	1	
4	STEM	A276-410	1	
5	BODY SEATRING	A240-304	1	WELDING
6	PACKING	NONASBESTOS	1SET	
7	PACKING GLAND	A216-WCB	1	
8-1	GLAND BOLT	STEEL		
8-2	GLAND NUT	STEEL		NYLON LOCK NUT
9-1	YOKE BOLT	STEEL	4	
9-2	YOKE NUT	STEEL	4	
10-1	DISC BOLT	A193-B8	2	
10-2	DISC NUT	A194-8	2	NYLON LOCK NUT
11	YOKE SLEEVE	BRASS	1	
12	THRUST WASHER	BRASS	1	
13	HAND WHEEL	A536-DCI	1	
14	NAME PLATE	ALUMINIUM	1	
15	LOCK WASHER	A240-304	1	
16	WHEEL NUT	STEEL	1	
17	BOTTOM STOPPER	A276-304	2	WELDING
18	RIVET	ALUMINIUM	2	
19	GREASE NIPPLE	ASS'Y	1	
20	BEARING HOUSING	A216-WCB	1	
21	THRUST BALL BEARING	ASS'Y	2	
22	BEARING GLAND	A216-WCB	1	TACK WELD
23-1	BEARING HOUSING BOLT	A193-B7	4	
23-2	BEARING HOUSING NUT	A194-2H	4	
24	BODY LINNER	A240-304	1SET	WELDING

* Resilient Seat Option : EPDM, Viton

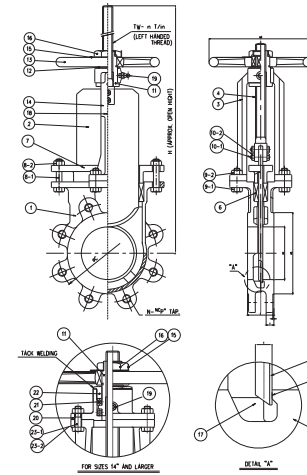

STAINLESS STEEL METAL SEAT/ RESILIENT SEAT KSM/KSR

Standard Materials

NO.	DESCRIPTION	MAT'L	Q'TY	REMARK
1	BODY	A351-CF8	1	
2	DISC	A240-304	1	
3	YOKE	A351-CF8	1	
4	STEM	A276-304	1	
5	BODY SEAT	A351-CF8	1	INTEGRAL
6	PACKING	NONASBESTOS	1SET	
7	PACKING GLAND	A351-CF8	1	
8-1	GLAND BOLT	A193-B8		
8-2	GLAND NUT	A194-8		NYLON LOCK NUT
9-1	YOKE BOLT	A193-B8	4	
9-2	YOKE NUT	A194-8	4	
10-1	DISC BOLT	A193-B8	2	
10-2	DISC NUT	A194-8	2	NYLON LOCK NUT
11	YOKE SLEEVE	BRASS	1	
12	THRUST WASHER	BRASS	1	
13	HAND WHEEL	A536-DCI	1	
14	NAME PLATE	ALUMINIUM	1	
15	LOCK WASHER	A240-304	1	
16	WHEEL NUT	STEEL	1	
17	BOTTOM WEDGE	A351-CF8	1	
18	RIVET	ALUMINIUM	2	
19	GREASE NIPPLE	ASS'Y	1	
20	BEARING HOUSING	A351-CF8	1	
21	THRUST BALL BEARING	ASS'Y	2	
22	BEARING GLAND	A351-CF8	1	TACK WELDING
23-1	BEARING HOUSING BOLT	A193-B8	4	
23-2	BEARING HOUSING NUT	A194-8	4	

* Resilient Seat Option : EPDM, Viton

DIMENSIONS TABLE

SIZE (inch)	L	ø d	ø G	ø C	N ^W P"	TW-n T/in	T	ø W	H
3	51.0	68	127	152.5	4-5/8"	18-(6)	8	180	400
4	51.0	90	157	190.5	8-5/8"	18-(6)	8	200	480
6	57.0	138	216	241.5	8-3/4"	20-(6)	8	250	620
8	70.0	186	270	298.5	8-3/4"	22.2-(6)	8	300	800
10	70.0	234	324	362.0	12-7/8"	25.4-(5)	10	350	960
12	76.0	282	381	432.0	12-7/8"	25.4-(5)	10	400	1100
14	76.0	323	413	476.0	12-1"	28.5-(4)	12	450	1240
16	89.0	362	470	539.5	16-1"	30-(4)	12	500	1370
18	89.0	412	533	578.0	16-1-1/8"	30-(4)	12	500	1530
20	114.0	462	584	635.0	20-1-1/8"	35-(4)	15	550	1720
24	114.0	555	692	749.5	20-1-1/4"	35-(4)	15	550	2010

* Note : 1. Flange rating is maker standard, but other standards are available on request.
2. Above Dimensions is subject to change without prior notice.

DIMENSIONS TABLE

SIZE (inch)	L	ø d	ø G	ø C	N ^W P"	t	f	TW-n	T	ø W	H
3	51.0	74	127	152.5	4-5/8"	15.0	2.0	18-6	8	180	430
4	51.0	102	157	190.5	8-5/8"	15.0	2.0	20-6	8	250	521
6	57.0	152	216	241.5	8-3/4"	16.0	2.5	20-6	8	250	658
8	70.0	198	270	298.5	8-3/4"	19.0	2.5	22-5	8	300	798
10	70.0	248	324	362.0	12-7/8"	21.0	2.5	26-5	10	350	989
12	76.0	304	381	432.0	12-7/8"	22.0	2.5	28-5	10	400	1147
14	76.0	336	413	476.0	12-1"	24.0	3.0	28-5	14	400	1280
16	89.0	385	470	539.5	16-1"	27.0	3.0	30-4	14	500	1478
18	89.0	438	533	578.0	16-1-1/8"	27.0	3.0	30-4	14	500	1523
20	114.0	488	584	635.0	20-1-1/8"	30.0	3.0	35-4	18	550	1811
24	114.0	590	692	749.5	20-1-1/4"	30.0	3.0	35-4	18	550	2102
26	114.0	641	749	806.5	24-1-1/4"	32.0	3.0	38-3.5	18	550	2356
30	121.0	743	857	914.5	28-1-1/4"	32.0	3.0	45-3	18	600	2656

* Note : 1. Flange rating is maker standard, but other standards are available on request.
2. Above Dimensions is subject to change without prior notice.

KNIFE GATE VALVE

Applicable for Slurry/Pulp/Ash

SPECIFICATION

1. MSS SP-81 specification for 150PSI
2. Flanges per ANSI B16.5
3. Size : 3" - 30"
4. Fluid : Power Plant, Waste water Treatment Plant, Slurry, Ash, Chemical Plant
5. Seat Sleeves : Gum Rubber

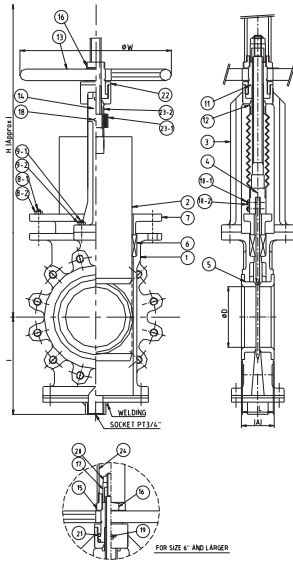

**CAST STEEL/SLEEVE
RESILIENT SEAT SLURRY SERVICE
KWS**

Standard Materials

NO.	DESCRIPTION	MAT'L	Q'TY	REMARK
1	BODY	A216-WCB	1	
2	DISC	A240-304	1	
3	YOKE	A216-WCB	1	
4	STEM	A276-410	1	
5	BODY SEAT SLEEVE	GUM RUBBER	2	
6	PACKING	NONASBESTOS	1SET	
7	PACKING GLAND	A216-WCB	1	
8-1	GLAND BOLT	STEEL		
8-2	GLAND NUT	STEEL		NYLON LOCK NUT
9-1	YOKE BOLT	STEEL	4	
9-2	YOKE NUT	STEEL	4	
10-1	DISC BOLT	A193-B8	2	
10-2	DISC NUT	A194-8	2	NYLON LOCK NUT
11	YOKE SLEEVE	BRASS	1	
12	YOKE RING	A36	1	TACK WELDING
13	HAND WHEEL	A536-DCI	1	
14	NAME PLATE	ALUMINIUM	1	
15	LOCK WASHER	A240-304	1	
16	WHEEL NUT	STEEL	1	
17	LOCK CAP	A276-304	1	
18	RIVET	ALUMINIUM	2	
19	GREASE NIPPLE	ASS`Y	1	
20	LOCK CAP NUT	A194-8	1	NYLON LOCK NUT
21	THRUST BALL BEARING	ASS`Y	1	
22	BEARING GLAND	A36	1	TACK WELDING
23-1	BOOTS	NBR	1	
23-2	BOOTS CLAMP	A240-304	2	
24	STEM COVER	A120	1	PIPE

* Seat sleeve Material Option : EPDM, Viton

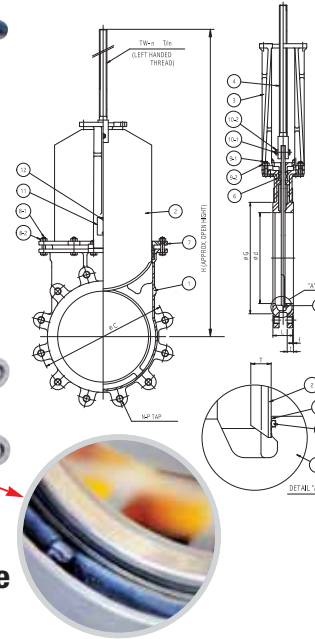

**Multi Seat Knife
Gate Valve
MSK**

Standard Materials

NO.	PART NAME	MATERIAL	Q'TY	REMARK
1	BODY	SCS13	1	
2	DISC	SUS304	1	
3	YOKE	SCS13	1	
4	STEM	SUS304	1	
5	METAL SEAT	A351-CF8	1	
5-1	SOFT SEAT	NBR O-RING	1	
6	PACKING	NONASBESTOS	1SET	
7	PACKING GLAND	SCS13	1	
8-1	GLAND BOLT	SUS304	1SET	
8-2	GLAND NUT	SUS304	1SET	NYLON LOCK NUT
9-1	YOKE BOLT	SUS304	4	
9-2	YOKE NUT	SUS304	4	
10-1	DISC BOLT	SUS304	2	
10-2	DISC NUT	SUS304	2	NYLON LOCK NUT
11	NAME PLATE	ALUMINIUM	1	
12	RIVET	ALUMINIUM	2	

DIMENSIONS TABLE

SIZE (inch)	L (A)	D	I	H	W
3	51 (58)	72	130	604	250
4	51 (58)	96	144	713	300
6	57 (64)	147	187	905	300
8	70 (77)	197	220	1035	400
10	70 (77)	246	255	1239	400
12	76 (83)	295	288	1406	400
14	76 (83)	339	316	1645	500
16	89 (96)	389	354	1774	550
18	89 (96)	437	389	1947	550
20	114 (119)	485	422	2013	600
24	114 (119)	585	482	2349	600
30	121 (127)	736	580	2850	780

* Note : 1. Flange rating is maker standard, but other standards are available on request.
2. Above Dimensions is subject to change without prior notice.

DIMENSIONS TABLE

SIZE (inch)	L	ø d	ø G	ø C	N ^o -P ^o	TW-n T/in	T	ø W	H
3	51.0	70	127	152.5	4-5/8"	18-(6)	8	180	400
4	51.0	96	157	190.5	8-5/8"	18-(6)	8	200	480
6	57.0	144	216	241.5	8-3/4"	20-(6)	8	250	620
8	70.0	188	270	298.5	8-3/4"	22.2-(6)	8	300	800
10	70.0	235	324	362.0	12-7/8"	25.4-(5)	10	350	960
12	76.0	288	381	432.0	12-7/8"	25.4-(5)	10	400	1100
14	76.0	319	413	476.0	12-1"	28.5-(4)	12	450	1240
16	89.0	365	470	539.5	16-1"	30-(4)	12	500	1370
18	89.0	416	533	578.0	16-1-1/8"	30-(4)	12	500	1530
20	114.0	463	584	635.0	20-1-1/8"	35-(4)	15	550	1720
24	114.0	560	692	749.5	20-1-1/4"	35-(4)	15	550	2010

* Note : 1. Flange rating is maker standard, but other standards are available on request.
2. Above Dimensions is subject to change without prior notice.